



Venus

AUTOCLAVABLE
PRESSURE
CONTROLLED
FERMENTERS/
BIOREACTORS



AUTOCLAVABLE PRESSURE CONTROLLED FERMENTERS/BIOREACTORS

VENUS

In addition to control parameters available in standard benchtop systems, the **Venus** platform offers the additional capability of Pressure Control.

In many fermentation product development cycles, over pressurization control is enabled only at pilot plant scales. Utilizing pressure control at the benchtop scale allows this parameter to be studied and better optimized, aiding considerations to gas mass transfer management when scaling up.

Venus greatly adds efficiency to the appropriate product development application.

VENUS typical applications includes the following:

- Education & Basic research
- Scale-up and scale-down studies
- Process development and optimization

VENUS can be used for:

- Biopharmaceutical
- Biofuels
- Food industry
- Bioremediation
- Bioplastic
- Cosmeceutical
- Nutraceutical



Pressure
controlled
up to 2 bar

**WHY TO
INVEST**
IN THIS PRODUCT

Removable jacket
before autoclaving:
Lighter & Handling
**Improved heat
transfer**

Higher oxygen
transfer

AUTOCLAVABLE PRESSURE CONTROLLED FERMENTERS/BIOREACTORS

VENUS

Benefits

Up to 24 units managed with one HMI with innovative **PARALLEL process control**
 LEONARDO: smart controller designed to provide a high level of automated management of the fermentation/cultivation processes



24" touch HMI

Batch, Fed batch or continuous processes

Different gas mixing strategies with up to 5 TMFC

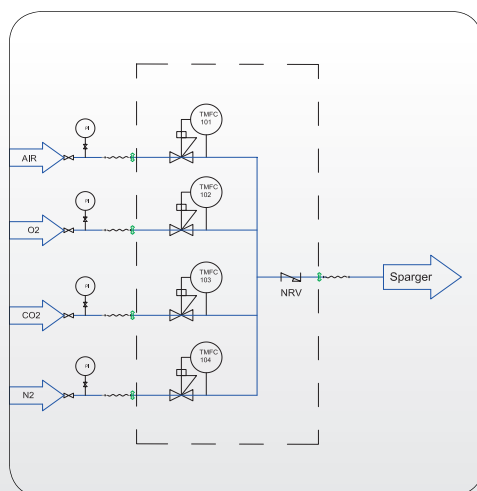

Powerful/ Accurate **brushless motor**, from 1 to 2000 RPM.
 Online absorbed Torques (Nm) and Power (W) measurements
 obtaining an indirect density indication of the culture broth

Modbus Digital sensors

Pressure controlled up to 2 bar
Easier scaling up
Higher oxygen transfer



Compact and modular PCS

N.4 assignable Watson Marlow pumps in entry level

Fully **removable and cleanable glass jacket** for an improved heat transfer during autoclaving



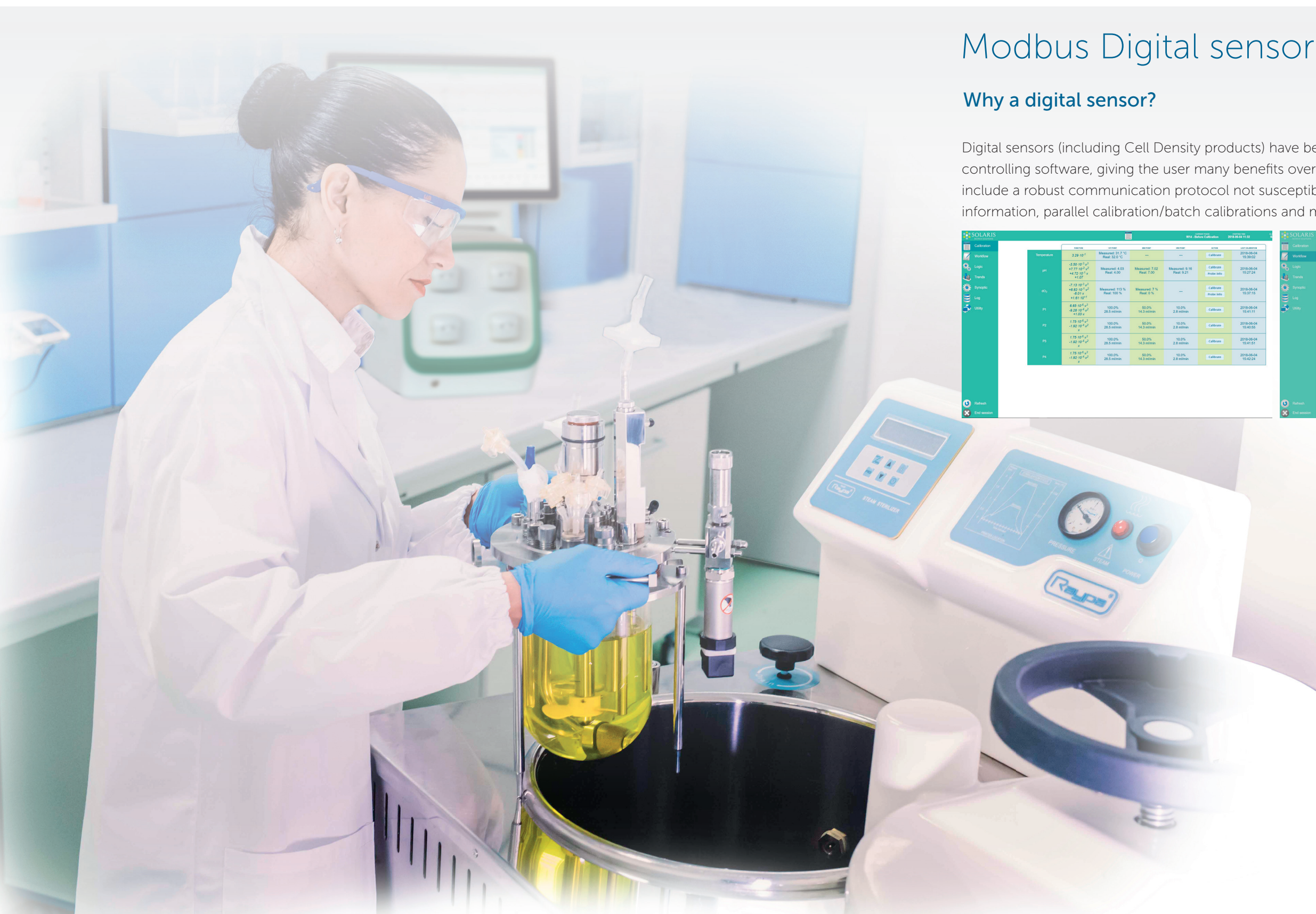

Modbus Digital sensors

Why a digital sensor?

Digital sensors (including Cell Density products) have been integrated to the Solaris PCS and Leonardo controlling software, giving the user many benefits over traditional analog sensor outputs. Such benefits include a robust communication protocol not susceptible to signal loss, in-software sensor diagnostic information, parallel calibration/batch calibrations and more.

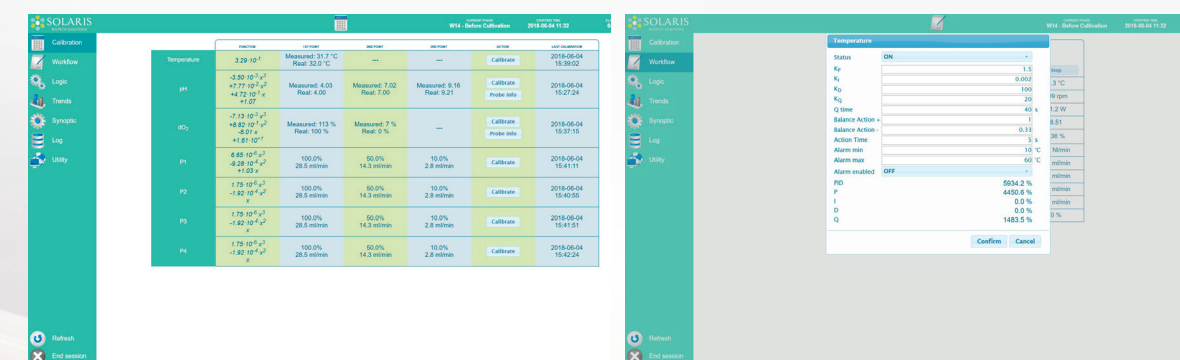

Sensor life traceability

Reducing background noise

GAS MIXING

Hardware and software adaptability are key to enable the best aeration strategy for each process. Thermal mass flow controllers (TMFC) allow precise flow rate control of individual gasses. Up to 5 TMFC's can be configured within each PCS cube and integrated to the controlling software. The powerful software and control platform allows precise cascade adjustment of multiple parameters to manage gas transfer, OTR, KLa, etc.

- n.1 TMFC included in "entry" level system; additional available as optional.
- Various agitator and baffle designs available
- Automatic gas mixing algorithms
- Toro, sintered and other spargers available

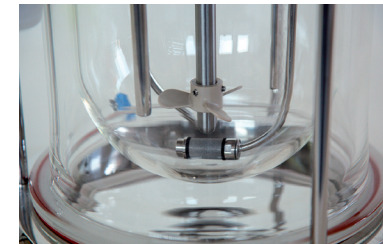

Leonardo 3.0 USER-FRIENDLY SOFTWARE



Solaris controlling software offers a simply laid out, yet powerful platform for experimental design planning and process control. The graphical user interface enables the intuitive selection and adjustment of control functions. Extracted data is compatible with Window Excel but, in addition, Solaris offers a platform where fermentation data can be easily exported in real time and thus managed. This software is included in the supply and can be installed on an unlimited number of the client's PC or laptops.

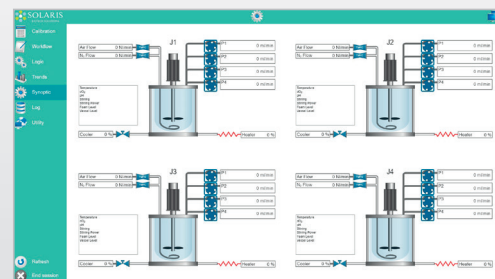

Parallel synoptic

Do it parallel: smarter..faster

Leonardo allows intuitive and time-saving parallel operations. Up to 24 independent fermentations/cultivations can be carried out simultaneously.

Leonardo 3.0

Do it wireless!

Increase mobility: users have the option to access the platform remotely via PC, tablet, phone. Remote access is multi-level password protected.

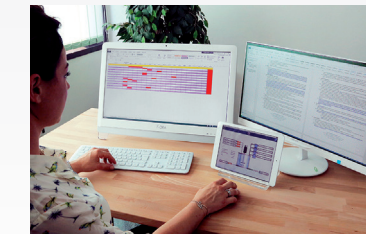
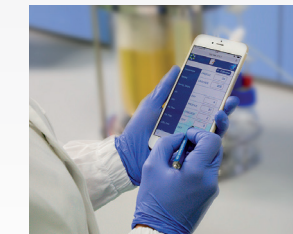
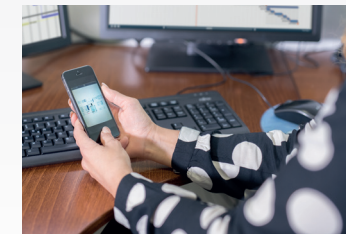

Smart PCS



Solaris new modular product design strategy decreases time to market and the number of unique parts in the product architecture, increasing the number of product variants. The result is a lean, flexible and smart PCS, which can be stacked in case of parallel processes through a dedicated support.



Additional parameters in modular external boxes for future PCS upgrade including dCO₂, Cell Density, Weight, Peristaltic pumps, ect.



Data sheet

| Vessel | | |
|---|--|-----------|
| Solaris Code | Venus 2.0 | Venus 4.0 |
| Production Code | vns110300 | vns130395 |
| Total Volume (liters) | 2,00 | 4,00 |
| Ratio D/H | 1:3,0 | 1:3,25 |
| Min. Working Volume (liters) | 0,35 | 0,60 |
| Max. Working Volume (liters) | 1,40 | 2,80 |
| Max. temperature | 70°C | |
| Operating pressure | 1.6 bar | 1.6 bar |
| Headplate Ports (n.10 Venus 2.0; n.13 Venus 4.0) | Venus 2.0: n.1 Agitation Group, n.1 Gas Sparger, n.1 Gas Overlay, n.1 Gas Out/Condenser, n.1 Sampling/Harvesting, n.1 Temperature, n.1 Multifeed, n.2 Sensors DN12, n.1 Spare Venus 4.0: n.1 Agitation Group, n.1 Gas Sparger, n.1 Gas Overlay, n.1 Gas Out/Condenser, n.1 Sampling, n.1 Harvesting, n.1 Temperature, n.1 Multifeed, n.2 Sensors DN12, n.3 Spare. | |
| Design | Borosilicate Glass Jacketed Vessel | |
| Materials | Borosilicate Glass and AISI 316 L | |
| pH | 325 | 425 |
| dO ₂ | 325 | 425 |
| Dimensions for autoclave (with Condenser) | | |
| Height (mm) | 619 | 705 |
| Diameter (mm) | 275 | 285 |
| Stirring | | |
| Drive | Brushless Motor | |
| Speed (rpm) | 1-1900 | 1-1800 |
| Nominal torque (Nm) | 0,9 | 0,9 |
| Impellers | Select from: Rushtons impellers, Marine Impellers, Pitched blade | |
| Thermoregulation | | |
| Control | PID Control - Accuracy 0,1 °C - Jacketed with n. 2 Electric Cartridge Heaters | |
| Total Heater Power (W) | 400 | 600 |
| Gas Control & Gas Mixing | | |
| Sparger and overlay Gas Control | TMFC with 0,22 µm sinterized filter | |
| Gas Mixing (Air,CO ₂ ,O ₂ ,N ₂) | n. 1 TMFC (included in entry level)+ n.4 solenoid valves or + n. of additional TMFC (up to 4) | |
| Sparger type | Select from: Toro type (ring), syntered microbubbling both provided with 0,2 µm filter | |
| Exhaust | Condenser and 0,22 µm filter | |
| Peristaltic Pumps | | |
| | n.4 Watson Marlow type 114, fixed speed, max. 60 rpm, volumetric flow 0,5-51 ml/min, function assignable from software | |
| | (optional) Watson Marlow type 313 FDM/D, max. speed 350 rpm, volumetric flow 1,5-1750 ml/min, function assignable from software | |
| Controller | | |
| Master Control Module | From 1 to 24 units - 35x37xh36 cm | |
| HMI with Leonardo software | Operate interface 58x15xh48 cm with 24" monitor | |

Controls

| INTEGRATED IN THE PCS | Temperature | |
|-----------------------|--|---|
| | Sensor | PT100 |
| | Accuracy | 0,1 °C |
| | Control system | Measuring resident in Leonardo 3.0 software |
| | Control range | 0 - 70°C |
| | pH | |
| | Sensor | Digital sensor |
| | Sensitivity | 57 to 59 mV/pH |
| | Control system | Measuring resident in Leonardo 3.0 software |
| | Control range | 0 - 14 |
| Operation temperature | 0 - 130°C | |
| Pressure range | 0 - 6 bar | |
| INTEGRATED IN THE PCS | dO ₂ | |
| | Sensor | Digital Optical sensor |
| | Accuracy | ±0.05%-vol, 21±0.2%-vol, 50±0.5%-vol |
| | Control system | Measuring resident in Leonardo 3.0 software |
| | Control range | 0,05 - 300% air saturation |
| | Operation temperature | -10 - 130°C |
| | Pressure range | 0 - 12 bar |
| | Antifoam/Level | |
| | Sensor | Solaris sensor |
| | Control | Measuring resident in Leonardo 3.0 software |
| INTEGRATED IN THE PCS | Redox (ORP) | |
| | Sensor | Digital sensor |
| | Sensitivity | 57 to 59 mV/pH |
| | Control system | Measuring resident in Leonardo 3.0 software |
| | Control range | ±2000 mV |
| | Operation temperature | - 10 -130°C |
| | Pressure range | < 6 bar |
| | Conductivity | |
| | Sensor | Digital sensor |
| | Accuracy | ±3% |
| Control system | Measuring resident in Leonardo 3.0 software | |
| Control range | 1 - 3000 µS/cm | |
| Operation temperature | 0 -130°C | |
| Pressure range | 0 - 20 bar | |
| INTEGRATED IN THE PCS | dCO ₂ | |
| | Sensor | Analog sensor |
| | Accuracy | ±10% (pCO ₂ 10-900 mbar) ≥ ±10%(pCO ₂ > 900 mbar)) |
| | Control system | Measuring resident in Leonardo 3.0 software |
| | Control range | 0,00-200% saturation |
| | Operation temperature | -20,0-150°C |
| | Cell density | |
| | Sensor | Digital sensor |
| | Accuracy | Mammalian cells in suspension ±5·10 ⁴ cells/ml - Fermentation ±0.05 g/l dry weight |
| | Control system | Measuring resident in Leonardo 3.0 software |
| Pressure range | 0-3 bar (option 1) 0-10 bar (option 2) | |
| Operation temperature | 0-60°C (option 1) 0-80°C (option 2) (max. sterilization temperature 135°C) | |
| Option 1 | Dencytee: Total cell density based on turbidity (Two ranges: 10 ⁵ to 10 ⁸ mammalian cells/ml - 0.5 to 100 g/L dry weight) | |
| Option 2 | Incyte: Viable cell density based on capacitance (Two ranges: 5x10 ⁵ to 8x10 ⁸ mammalian cells/ml - 5 to 200 g/L dry weight) | |
| EXTERNAL MODULAR BOX | Weight | |
| | Sensor | Digital Balance |
| | Accuracy | ±0.2 g |
| | Control | Measuring resident in Leonardo 2.0 software |
| | Peristaltic pumps | |
| | WM 114 | 10-60 rpm |

Chiller

- Optionally VENUS can be equipped with a chiller for heat removal from your culture minimizing lab water usage
- Using this system you don't need a water supply line in your lab
- Cost-effective cooling of fermenters
- Easy operation
- Refrigerant level monitoring



Chiller data sheet

| | |
|---|---------------|
| Working temperature range | -10°C / +40°C |
| Temperature stability | ±0.5 |
| Power consumption | 0.7 kW |
| Filling volume range | 2-8 L |
| Cooling output at 20°C measured with ethanol | 0.25-0.60 kW |
| Cooling output at 10°C measured with ethanol | 0.20-0.50 kW |
| Cooling output at 0°C measured with ethanol | 0.15-0.36 kW |
| Cooling output at -10°C measured with ethanol | 0.09-0.15 kW |
| Pump pressure max. | 0.35-1.30 bar |
| Pump flow max. | 16-35 L/min. |

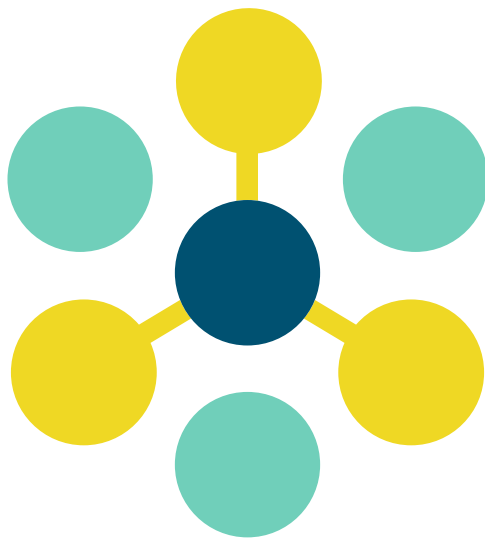

SOLARIS

BIOTECH SOLUTIONS

Distributed by:

Lab Unlimited
CARL STUART GROUP

Tallaght Business Park
Whitestown, Dublin 24,
Ireland
D24 RFK3

Tel: (01) 4523432
Fax: (01) 4523967
E-mail: info@labunlimited.com
Web: www.labunlimited.com

Quatro House, Frimley Road,
Camberley,
United Kingdom
GU16 7ER

Tel: 08452 30 40 30
Fax: 08452 30 50 30
E-mail: info@labunlimited.co.uk
Web: www.labunlimited.co.uk